

- 1
- 2
- 3
- 4
- 5
- 6
- 7
- 8
- 9
- 10
- 11
- 12
- 13
- 14
- 15
- 16
- 17
- 18

**HANDLE SHANKS**

Die-cast zinc alloy, epoxy resin coating, RAL 9005 black colour, matte finish. Fixed to the oval tube by a screw.

**END CAPS**

Polyamide based (PA) technopolymer, light grey colour.

**STANDARD EXECUTIONS**

Back mounting, threaded blind holes:

- **GN 335-A-EL**: anodised aluminium tube, natural colour.
- **GN 335-A-SW**: aluminium tube, epoxy resin coating, RAL 9005 black colour, matte finish.

Front mounting by means of AISI 304 stainless steel screws, nuts and washers, included in the supply:

- **GN 335-B-EL**: anodised aluminium tube, natural colour.
- **GN 335-B-SW**: aluminium tube, epoxy resin coating, RAL 9005 black colour, matte finish.

**FEATURES AND APPLICATIONS**

The GN 335 tubular handles are at a 45° inclination of the tube axes.

These handles are typically used on turning or rolling doors for machines and equipment.

**SPECIAL EXECUTIONS ON REQUEST**

Different lengths.

Handles with oval tube in anodized aluminium, natural colour and RAL 9006 light grey supports.

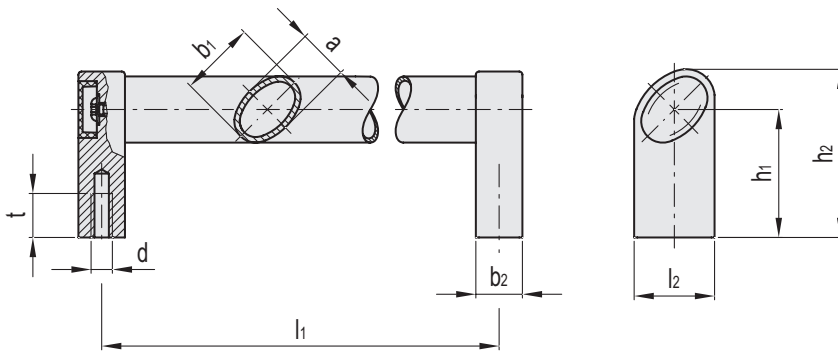
**GN 335-A**

Code	Description	b1	l1	d	b2	a	h1	h2	l2	tmin	⚖️
GN.16831	GN 335-36-200-A-EL	36	200	M8	22	24	60.5	79.5	38	15	1061
GN.16833	GN 335-36-200-A-SW	36	200	M8	22	24	60.5	79.5	38	15	500
GN.16839	GN 335-36-250-A-EL	36	250	M8	22	24	60.5	79.5	38	15	1093
GN.16841	GN 335-36-250-A-SW	36	250	M8	22	24	60.5	79.5	38	15	1136
GN.16847	GN 335-36-300-A-EL	36	300	M8	22	24	60.5	79.5	38	15	1133
GN.16849	GN 335-36-300-A-SW	36	300	M8	22	24	60.5	79.5	38	15	1128
GN.16855	GN 335-36-400-A-EL	36	400	M8	22	24	60.5	79.5	38	15	1258
GN.16857	GN 335-36-400-A-SW	36	400	M8	22	24	60.5	79.5	38	15	1264
GN.16863	GN 335-36-500-A-EL	36	500	M8	22	24	60.5	79.5	38	15	1278
GN.16865	GN 335-36-500-A-SW	36	500	M8	22	24	60.5	79.5	38	15	1293
GN.16871	GN 335-36-600-A-EL	36	600	M8	22	24	60.5	79.5	38	15	1430
GN.16873	GN 335-36-600-A-SW	36	600	M8	22	24	60.5	79.5	38	15	1368
GN.16879	GN 335-36-800-A-EL	36	800	M8	22	24	60.5	79.5	38	15	1601
GN.16881	GN 335-36-800-A-SW	36	800	M8	22	24	60.5	79.5	38	15	1522

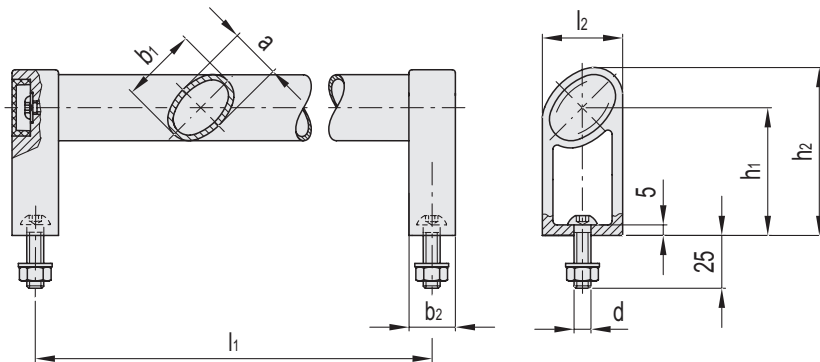

## GN 335-B

Code	Description	b1	l1	d	b2	a	h1	h2	l2	⚖
GN.16835	GN 335-36-200-B-EL	36	200	M8	22	24	60.5	79.5	38	1029
GN.16837	GN 335-36-200-B-SW	36	200	M8	22	24	60.5	79.5	38	1061
GN.16843	GN 335-36-250-B-EL	36	250	M8	22	24	60.5	79.5	38	1061
GN.16845	GN 335-36-250-B-SW	36	250	M8	22	24	60.5	79.5	38	1104
GN.16851	GN 335-36-300-B-EL	36	300	M8	22	24	60.5	79.5	38	560
GN.16853	GN 335-36-300-B-SW	36	300	M8	22	24	60.5	79.5	38	1096
GN.16859	GN 335-36-400-B-EL	36	400	M8	22	24	60.5	79.5	38	1226
GN.16861	GN 335-36-400-B-SW	36	400	M8	22	24	60.5	79.5	38	1232
GN.16867	GN 335-36-500-B-EL	36	500	M8	22	24	60.5	79.5	38	1246
GN.16869	GN 335-36-500-B-SW	36	500	M8	22	24	60.5	79.5	38	1261
GN.16875	GN 335-36-600-B-EL	36	600	M8	22	24	60.5	79.5	38	1399
GN.16877	GN 335-36-600-B-SW	36	600	M8	22	24	60.5	79.5	38	1336
GN.16883	GN 335-36-800-B-EL	36	800	M8	22	24	60.5	79.5	38	1569
GN.16885	GN 335-36-800-B-SW	36	800	M8	22	24	60.5	79.5	38	1490

